



**Facility Study
For
Generation Interconnection
Request
GEN-2012-032**

*SPP Generation
Interconnection Studies*

(#GEN-2012-032)

July 2013

Revision History

Date	Author	Change Description
7/08/2013	SPP	Facility Study Report Issued

Summary

Oklahoma Gas and Electric (OKGE) performed a detailed Facility Study at the request of Southwest Power Pool (SPP) for Generation Interconnection request GEN-2012-032 (300.0 MW/Wind) located in Kay County, Oklahoma. The originally proposed in-service date for GEN-2012-032 was November 15, 2014. SPP has proposed the in-service date will be after the assigned Interconnection Facilities and Non-Shared network upgrades are completed. Full Interconnection Service will require the Network Upgrades listed in the “Other Network Upgrades” section. The request for interconnection was placed with SPP in accordance with SPP’s Open Access Transmission Tariff, which covers new generation interconnections on SPP’s transmission system.

Phases of Interconnection Service

It is not expected that interconnection service will require phases however, interconnection service will not be available until all interconnection facilities and network upgrades can be placed in service.

Interconnection Customer Interconnection Facilities

The Interconnection Customer will be responsible for all of the transmission facilities connecting the customer owned substation to the Point of Interconnection (POI), at Oklahoma Gas and Electric (OKGE) substation tapping the Rose Hill – Sooner 345kV transmission line. This new 345kV substation is currently planned to be constructed for GEN-2012-041 Interconnection Facilities. The Interconnection Customer will also be responsible for any equipment located at the Customer substation necessary to maintain a power factor of 0.95 lagging to 0.95 leading at the POI.

Transmission Owner Interconnection Facilities and Non-Shared Network Upgrades

To allow interconnection the Transmission Owner will need to construct an addition terminal and breaker along with associated terminal equipment for acceptance of the Interconnection Customer’s Interconnection Facilities. At this time GEN-2012-032 is responsible for \$3,654,353.00 of Transmission Owner Interconnection Facilities and Non-Shared Network Upgrades. Oklahoma Gas and Electric (OKGE) will need to reevaluate costs GEN-2012-032 if for unforeseen reason the new 345kV substation is not constructed under GEN-2012-041.

Shared Network Upgrades

The Interconnection Customer was studied within the DISIS-2012-002 Impact Study. At this time, the Interconnection Customer is allocated \$0.00 for Shared Network Upgrades. If higher queued interconnection customers withdraw from the queue, suspend or terminate their GIA, restudies will have to be conducted to determine the Interconnection Customers’ allocation of Shared Network Upgrades. All studies have been conducted on the basis of higher queued interconnection requests and the upgrades associated with those higher queued interconnection requests being placed in service. At this time, the Interconnection Customer is allocated the following cost for Shared Network Upgrade:

Share Network Upgrade Description	Allocated Cost	Total Cost
None	\$0.00	\$0.00
Total	\$0.00	

Other Network Upgrades

Certain Other Network Upgrades are currently not the cost responsibility of the Customer but will be required for full Interconnection Service. At this time, No Other Network Upgrades are currently assigned to this Interconnection Customer.

Depending upon the status of higher or equally queued customers, the Interconnection Customer's in-service date is at risk of being delayed or their Interconnection Service is at risk of being reduced until the in-service date of these Other Network Upgrades.

Conclusion

Interconnection Service for GEN-2012-032 will be delayed until the Transmission Owner Interconnection Facilities and Non-Shared Network Upgrades are constructed. The Interconnection Customer is responsible for \$3,654,353.00 of Transmission Owner Interconnection Facilities and Non-Shared Network Upgrades. At this time, the Interconnection Customer is allocated \$0.00 for Shared Network Upgrades. After all Interconnection Facilities and Network Upgrades have been placed into service, Interconnection Service for 300 MW, as requested by GEN-2012-032, can be allowed. At this time the total allocation of costs assigned to GEN-2012-032 for Interconnection Service are estimated at \$3,654,353.00.



FACILITY STUDY

for

Generation Interconnection Request 2012-032

300 MW Wind Generating Facility
In Kay County
Near
Newkirk, Oklahoma

June 04, 2013

Steve M. Hardebeck, PE
Lead Engineer
Transmission Planning
OG&E Electric Services

Summary

Pursuant to the tariff and at the request of the Southwest Power Pool (SPP), Oklahoma Gas and Electric (OG&E) performed the following Facility Study to satisfy the Facility Study Agreement executed by the requesting customer for SPP Generation Interconnection request Gen-2012-032. The request for interconnection was placed with SPP in accordance SPP's Open Access Transmission Tariff, which covers new generation interconnections on SPP's transmission system. The requirements for interconnection consist of adding a new 345kV breaker and a terminal in the new proposed OG&E substation proposed under 2012-041, Ranch Substation, which is approximately 7 miles south of the proposed wind farm location. The total cost for OKGE to add a new 345kV breaker and a terminal for the wind farm line into the proposed new Ranch substation, is estimated at \$3,654,353. If for unforeseen reasons Ranch substation is not constructed under Gen-2012-041 the interconnection cost for this interconnection Gen-2012-032 could increase. The increased cost would be the responsibility of the Interconnection Customer under this Gen-2012-032.

Table of Contents

Table of Contents	3
Introduction	4
Interconnection Facilities	5
Interconnection Costs	6
One-Line diagram of Interconnection	7

Introduction

The Southwest Power Pool has requested a Facility Study for the purpose of interconnecting 300MW of wind generation within the service territory of OG&E Electric Services (OKGE) in Kay County Oklahoma. The proposed 345kV point of interconnection is at the proposed OG&E Ranch Substation in Kay County. The proposed in-service date is August 1, 2014.

Power flow analysis has indicated that for the power flow cases studied, it is possible to interconnect the 300MW of generation within the local transmission system. Given the Point of Interconnection at an existing substation, there are additional requirements for interconnection including bus, breakers, switches, relaying, metering, etc.

The cost for adding a new 345kV terminal to the proposed New Substation, the required interconnection facility, is estimated at \$1,099,958. Other Network Constraints in the American Electric Power West (AEPW), OKGE, Western Farmers Electric Cooperative (WFEC), and Western Resources(Westar) systems may be verified with a transmission service request and associated studies.

Interconnection Facilities

The primary objective of this study is to identify attachment facilities. The requirements for interconnection consist of adding a new 345kV terminal in the New Substation. This 345kV addition shall be constructed and maintained by OKGE. The Customer did not propose a route of its 345kV line to serve its 345-34.5kV facilities. It is assumed that obtaining all necessary right-of-way for the new OKGE 345kV substation facilities will not be a significant expense.

The total cost for OKGE to add a new 345kV terminal in the new substation, the interconnection facility, is estimated at \$1,099,958. This cost does not include building 345kV line from the Customer substation into the New Substation. The Customer is responsible for this 345kV line up to the point of interconnection. This cost does not include the Customer's 345-34.5kV substation and the cost estimate should be determined by the Customer.

This Facility Study does not guarantee the availability of transmission service necessary to deliver the additional generation to any specific point inside or outside the Southwest Power Pool (SPP) transmission system. The transmission network facilities may not be adequate to deliver the additional generation output to the transmission system. If the customer requests firm transmission service under the SPP Open Access Transmission Tariff at a future date, Network Upgrades or other new construction may be required to provide the service requested under the SPP OATT.

The costs of interconnecting the facility to the OKGE transmission system are listed in Table 1.

Short Circuit Fault Duty Evaluation

It is standard practice for OG&E to recommend replacing a circuit breaker when the current through the breaker for a fault exceeds 100% of its interrupting rating with re-closer de-rating applied, as determined by the ANSI/IEEE C37.5-1979, C37.010-1979 & C37.04-1979 breaker rating methods.

For this generator interconnection, no breakers were found to exceed their interrupting capability after the addition of the Customer’s 300 MW generation and related facilities. OG&E found no breakers that exceeded their interrupting capabilities on their system. Therefore, there is no short circuit upgrade costs associated with the Gen-2012-032 interconnection.

Table 1: Required Interconnection Network Upgrade Facilities

Facility	ESTIMATED COST (2013 DOLLARS)
OKGE – Interconnection Facilities - Add a single 345kV line terminal to a new Substation. Dead end structure, line switches, line relaying, revenue metering including CTs and PTs	\$1,099,958
OKGE – Network Upgrades At the new sub add 1-345kV breaker, line relaying, disconnect switches, and associated equipment.	\$2,554,395
OKGE - Right-of-Way for 345kV terminal addition	No Additional ROW
Total	\$3,654,353

Prepared by Steve M. Hardebeck, PE
Lead Engineer, Transmission Planning
OG&E Electric Services

June 04, 2013

Reviewed by:

Travis D. Hyde
Travis D. Hyde - P.E.
Director, T&D Planning

New Sooner to Western Resources Rose Hill 345kV Substation Ranch Substation

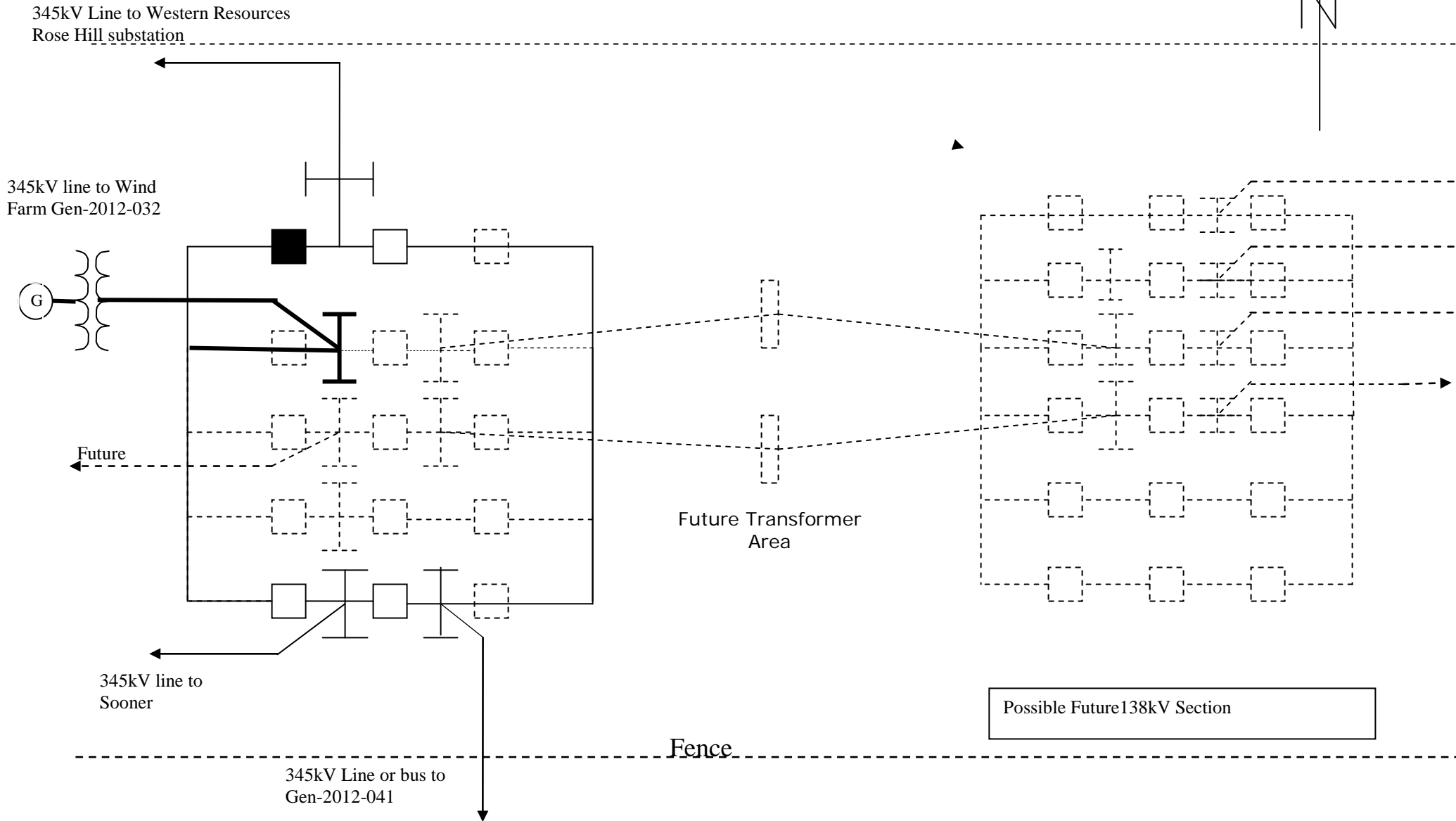

103MW Nominal combustion turbine